

MV-ID2013EM

1.3 MP Smart Code Reader



Introduction

MV-ID2013EM smart code reader can read different types of 1-dimensional and 2-dimensional codes, and its max. reading speed reaches 30 codes/sec. It adopts deep learning algorithm to process images with good robustness, and can recognize various codes.

Key Feature

- Built-in deep learning algorithm to read codes with good robustness.
- Compact design and small in size.
- Adopts multiple IO interfaces and plug-in power interface.
- Adopts LED aiming light to help aim codes.
- Adopts buzzer and indicator for indicating device status.
- Supports one-click parameter adjustment for convenient operation.

Available Model

- White light source with network interface: MV-ID2013EM-05-WBN
- White light source (polarized) with network interface: MV-ID2013EM-05-WBP
- Red light source with network interface: MV-ID2013EM-05-RBN
- Red light source (polarized) with network interface: MV-ID2013EM-05-RBP
- White light source with USB interface: MV-ID2013EM-05-WBN-U
- White light source (polarized) with USB interface: MV-ID2013EM-05-WBP-U
- Red light source with USB interface: MV-ID2013EM-05-RBN-U
- Red light source (polarized) with USB interface: MV-ID2013EM-05-RBP-U

Applicable Industry

Consumer electronics, household appliances, food and beverage, pharmaceutical, semiconductor, automobile parts, ticket checking machine, etc.



Specification

| Model | MV-ID2013EM-05-WBN(-U) | MV-ID2013EM-05-WBP(-U) | MV-ID2013EM-05-RBN(-U) | MV-ID2013EM-05-RBP(-U) |
|-------------------------------|--|------------------------|------------------------|------------------------|
| Performance | | | | |
| Symbologies | 1-dimensional codes: Code 39, Code 93, Code 128, ITF 14, ITF 25, CodaBar, EAN 8, EAN 13, UPCA, UPCE | | | |
| | 2-dimensional codes: QR Code, Data Matrix | | | |
| Max. frame rate | 50 fps | | | |
| Max. reading speed | 30 codes/sec | | | |
| Sensor type | CMOS, global shutter | | | |
| Pixel size | 2.7 μm \times 2.7 μm | | | |
| Sensor size | 1/4" | | | |
| Resolution | 1280 \times 1024 | | | |
| Exposure time | 60 μs to 6000 μs | | | |
| Gain | 1 dB to 28 dB | | | |
| Mono/color | Mono | | | |
| Communication protocol | Device with network interface: SmartSDK, TCP Client, Serial, FTP, HTTP, TCP Server, UDP | | | |
| | Device with USB interface: SmartSDK, USB (HID, CDC) | | | |
| Depth of field* | Code 39 (5 mil): 75 mm to 215 mm Code 128 (10 mil): 50 mm to 400 mm EAN 13 (13 mil): 60 mm to 420 mm Data Matrix (10 mil): 50 mm to 240 mm QR Code (15 mil): 40 mm to 290 mm | | | |
| Optics | | | | |
| Focal length | 4.7 mm (0.2") | | | |
| Working distance | 120 mm (4.7") | | | |
| Ambient illumination | 900 lux@120 mm | | | |
| Light source | White | White (polarized) | Red | Red (polarized) |
| Aiming system | Green LED | | | |
| Electrical feature | | | | |
| Data interface | Device with network interface: Fast Ethernet | | | |
| | Device with USB interface: USB2.0 | | | |
| Digital I/O | Device with network interface: DB15 connector provides power and I/O, including none-isolated input \times 2 (LineIn 0/1), none-isolated output \times 2 (LineOut 2/3), RS-232 \times 1. Device trigger via pressing trigger button supported. | | | |
| | Device with USB interface: DB15 connector provides data transmission. Device trigger via pressing trigger button supported. | | | |
| Power supply | Device with network interface: 12 VDC to 24 VDC | | | |
| | Device with USB interface: 5 VDC (USB2.0 provides power supply) | | | |
| Max. power consumption | Device with network interface: 3.5 W@12 VDC | | | |
| | Device with USB interface: 2.5 W@5 VDC (USB2.0 provides power supply) | | | |

| Mechanical | |
|---------------------------|---|
| Lens mount | M5.8-mount |
| Indicator | Power indicator (POWER), status indicator (OK/NG) |
| Dimension | 45 mm × 43 mm × 25 mm (1.8" × 1.7" × 1.0") |
| Weight | Approx. 68.5 g (0.15 lb.) |
| Ingress protection | IP54 |
| Temperature | Working temperature: 0 °C to 50 °C (32 °F to 122 °F) storage temperature: -30 °C to 70 °C (-22 °F to 158 °F) |
| Humidity | 20% to 95% RH, non-condensing |
| General | |
| Client software | IDMVS |
| Certification | CE, FCC, RoHS |

*Test condition: Environment temperature=25 °C (77 °F), ambient illumination=250 lux filament lamp, sample symbologies are used.

Dimension

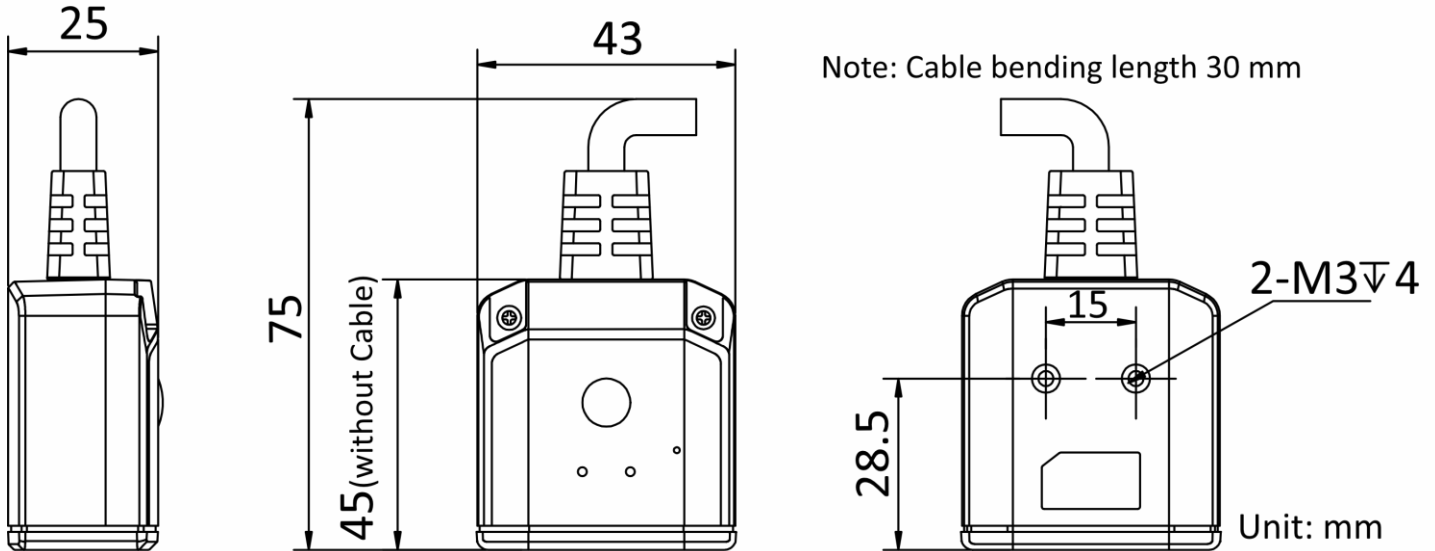

HIKROBOT

Hangzhou Hikrobot Technology Co., Ltd.
No.399 Danfeng Road, Binjiang District, Hangzhou 310051, China.
en.hikrobotics.com

Copyright Hikrobot

Hangzhou Hikrobot Technology Co., Ltd. All Rights Reserved. Hangzhou Hikrobot Technology does not tolerate any infringement. Any organization or individual may not imitate or reproduce in whole or in part of the content. The data herein is based on Hikrobot's internal evaluation. Actual data may vary depending on specific configuration and operating condition. The information herein is subject to change without notice All the content has been checked conscientiously. Nevertheless, Hikrobot shall not be liable to damages resulting from errors, inconsistencies or omissions.